

LOC		DIST		P		F		ZONE		LTR		REVISIONS		DATE	APPD		
CM	53												E	REV PER EC	0L30-0034-96	8-30-96	JH

1. BULK PACKAGED, UNASSEMBLED.
2. APPROVAL AGENCY LOGO LOCATED APPROXIMATELY AS SHOWN.
3. AMP LOGO LOCATED THIS SURFACE.
4. CIRCUIT NUMBER ONE IDENTIFICATION RIB AND CIRCUIT IDENTIFICATION NUMBERS ARE EACH LOCATED ADJACENT TO THE APPROPRIATE CIRCUIT CAVITIES.
5. NEW MOLD CONSTRUCTION PROVIDES MATERIAL REDUCTION CORING AT BASE OF SILOS WITH NO CORING AS OPTIONAL.
6. DIMENSION INDICATED IS AS MOLDED. ADDITIONAL GROWTH DUE TO SUBSEQUENT MOISTURE ABSORPTION MAY OCCUR.

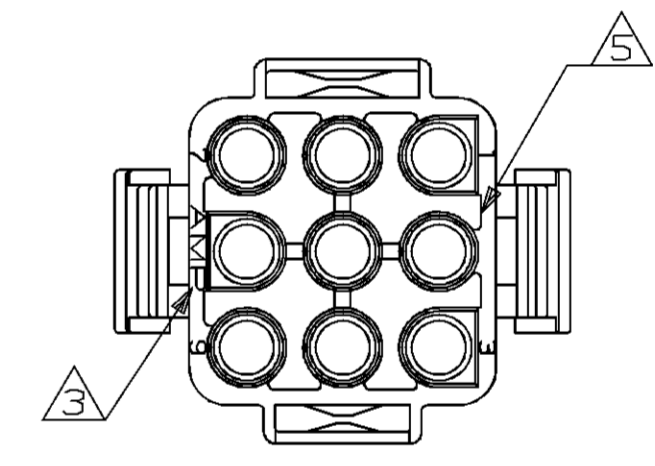
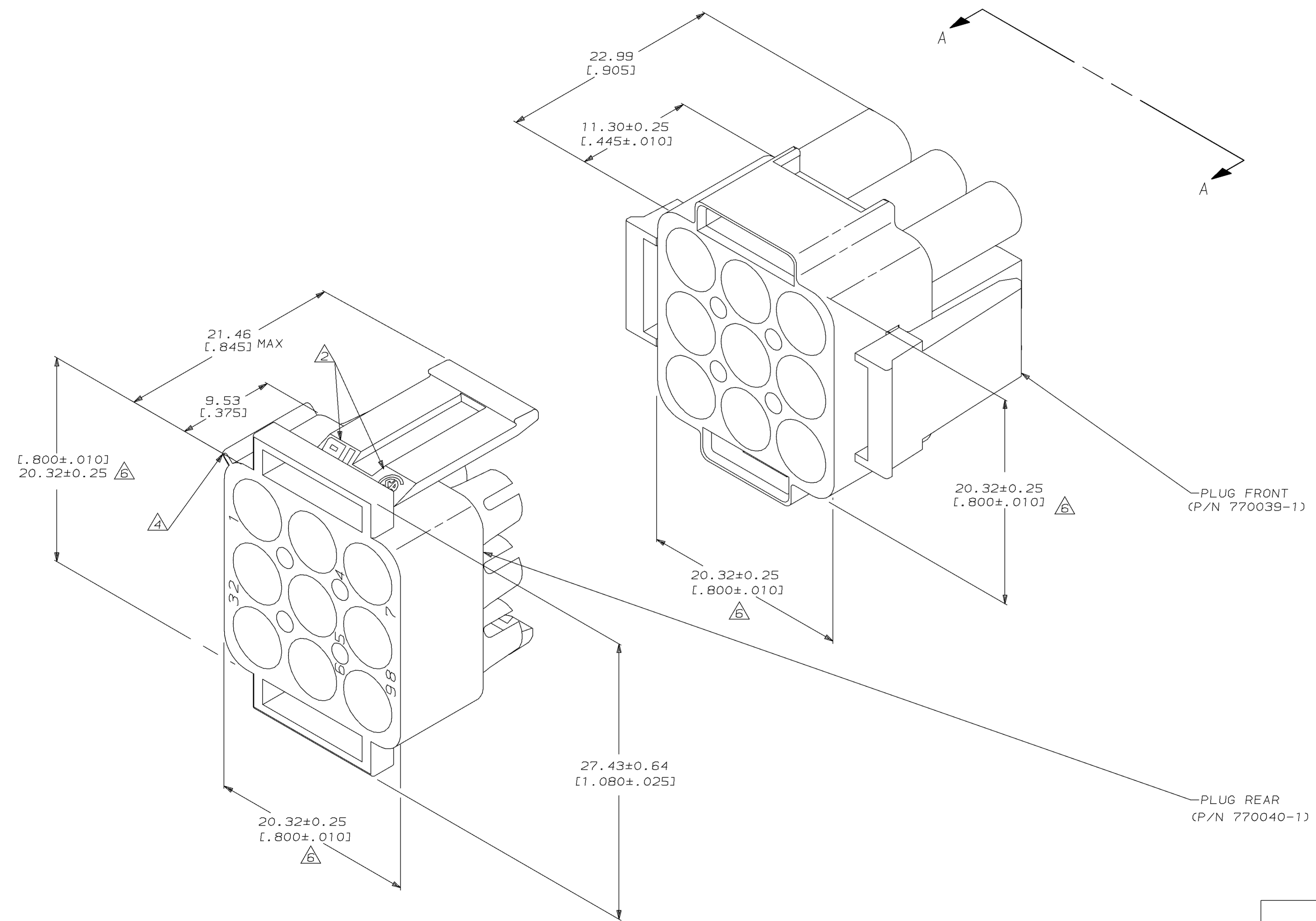

VIEW A-A  
SCALE 2:1

770021-1  
PART NUMBER

DO NOT SCALE PRINT. UNLESS SPECIFIED DIMENSIONS IN INCHES TOLERANCES ON:		DR 1-22-92 K. SALMON		PART NO	
1. ± .005		CHK 1-22-92 R. SWING		AMP INCORPORATED Harrisburg, Pa. 17105	
2. PLC DEC ± 0.13 [.005]		APPD 1-22-92 M. TRULL		NAME	
3. ANGLES ±		APPD 1-22-92 M. TRULL		PLUG HOUSING KIT, 9 CIRCUIT, UNIVERSAL MATE-N-LOK™ II	
MATERIAL		PRODUCT SPEC		SIZE	
NYLON, UL94V-0,		APPLICATION SPEC		D 00779	
FINISH		WEIGHT		DRAWING NO	
				770021	
				SCALE	
				5:1	
				SHEET	
				1 OF 1	

